

EE21 Series

High-Precision Humidity / Temperature Transmitter for HVAC Applications

Transmitters of the EE21 series have been developed for high-precision measurement of relative humidity and temperature.

EE21 transmitters are available for wall and duct mounting with or without the very useful snap in-mounting kit, which allows a quick and easy exchange of the transmitter. Outputs can be selected between voltage and current.

An optional radiation shield providing a forced ventilation is recommended for use in outdoor applications.

Special protection coating for the sensing element (code - HC) permits the permanent use in very polluted environments.

High humidity calibration is recommended for applications in high lasting humidities > 90% RH (Code - CA01).



Humidity Two-point Adjustment

With an easy routine via the push-buttons "UP" and "DOWN" on the circuit board the user can perform a fast and accurate two-point adjustment of relative humidity.



Typical Applications

- green houses
- storage rooms
- swimming halls
- meteorology

Features

- measuring range 0...100% RH
- accuracy ±2% RH
- traceable calibration
- working range -40...60°C (-40...140°F)
- wettable
- excellent long term stability

Technical Data

Measuring values

Relative Humidity

Sensor	HC1000 or HC1000C (with coating)	
Analogue output appropriate 0...100% RH	0-1V	-0.5mA < I _L < 0.5mA
	0-5V / 0-10V	-1mA < I _L < 1mA
	4-20mA (two wires)	R _L < 500 Ohm

Working range ¹⁾	0...100% RH	
Accuracy at 20°C (68°F)	± 2% RH (0...90%)	± 3% RH (90...100%)
	Traceable to international standards, administrated by NIST, PTB, BEV...	

Hysteresis 10% - 80% - 10%	< 2% RH	
Temperature dependence of electronics	typ. 0.03% RH/°C	(0.02% RH/°F)
Temperature dependence of probe	typ. 0.03% RH/°C	(0.02% RH/°F)

Temperature

Sensor	Pt1000 (tolerance class A, DIN EN 60751)	
Analogue output -40...60°C (-40...140°F)	0-1V	-0.5mA < I _L < 0.5mA
	0-5V / 0-10V	-1mA < I _L < 1mA
	4-20mA (two wires)	R _L < 500 Ohm

Accuracy (typ.)

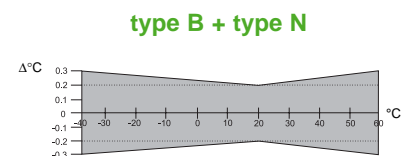
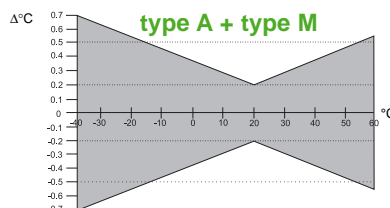

Temperature dependence of electronics	typ. 0.01°C /°C
---------------------------------------	-----------------

General

Supply	for 0 - 1V for 0 - 5V for 0 - 10V for 4 - 20mA	10 - 35V DC 12 - 35V DC 15 - 35V DC 10V +R _L x 0,02 < U _V < 35V DC; R _L < 500 Ohm	or	9 - 29V AC 15 - 29V AC 15 - 29V AC
Current consumption		for DC supply: typ. 5mA		for AC supply: typ. 15mA _{eff}
Electrical connection		screw terminals max. 1.5 mm ² (AWG 16)		
Cable gland		M16x1.5 or connection plug (only snap-in models N + M) cable Ø 4.5 - 10 mm (0.18 - 0.39")		
Sensor protection		membrane filter, sintered stainless steel filter, metal grid filter, PTFE filter		
Electromagnetic compatibility		EN 61000-6-2 EN 61000-6-3	ÖVE EN 61326-1+A1+A2 FCC Part15 ClassB	ICES-003 ClassB CE
Temperature ranges		working temperature probe: working temperature electronics: storage temperature:		-40...60°C (-40...140°F) -40...60°C (-40...140°F) -25...60°C (-13...140°F)

1) Please refer to working range of HC1000!

Dimensions (mm)

1 mm = 0.03937" / 1" = 25.4 mm

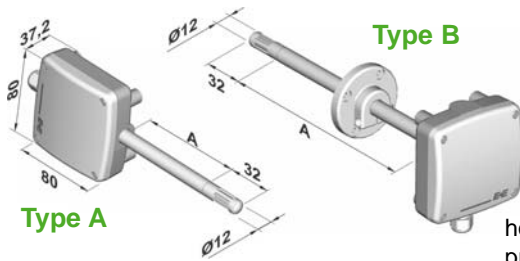

housing: PC
 protection class: IP65, Nema 4

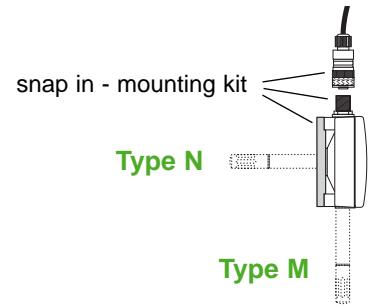

Connection Diagram

EE21-FT1/2/3xxx / EE21-F1/2/3xxx

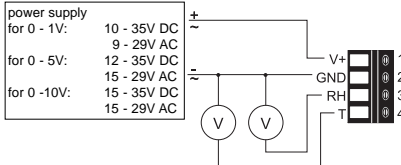

EE21-FP3xxx

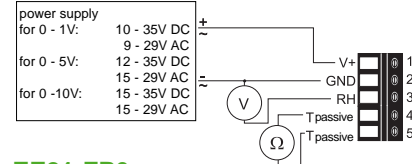

EE21-FT6xxx / EE21-F6xxx

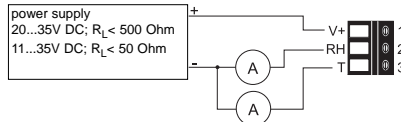

EE21-FP6xxx

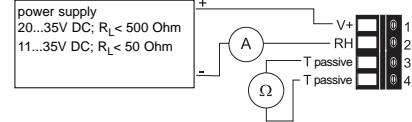

Ordering Guide

MODEL	OUTPUT	T-SENSOR (only passive)	HOUSING TYPE	PROBE LENGTH (see dimensions "A")	FILTER
humidity + temperature (FT)	0 - 1 V (1)	Pt 100 DIN A (A)	wall mounting (A)	50 mm (1.9") (2)	membrane filter (1)
humidity (F)	0 - 5 V (2)	Pt 100 DIN B (B)	duct mounting (B)	200 mm (7.9") (5)	sintered stainless steel filter (3)
humidity+temp. passive (FP)	0 - 10 V (3)	Pt 1000 DIN A (C)	snap in - wall mounting ¹⁾ (M)	others (x)	PTFE filter (5)
	4 - 20 mA (6)	Pt 1000 DIN B (D)	snap in - duct mounting ¹⁾ (N)		metal grid filter (6)
EE21-					

COATING	CALIBRATION	T-UNIT	SCALING OF T-OUTPUT
no (no code)	standard (no code)	°C (no code)	-40...60 (T02) -40...140 (T83)
yes (HC01)	high humidity (CA01)	°F (E01)	-30...70 (T08) 0...176 (T86)
			-20...80 (T24) 32...132 (T96)
			other (Txx)

Order Example

EE21-FT3A26-CA01/T24
 model: RH/T transmitter
 output: 0 - 10V
 housing type: wall mounting
 probe length: 50 mm (7.9")
 filter: metal grid filter
 sensor coating: no
 calibration: high humidity
 T-unit: °C
 Scaling of T-output: -20...80°C

1) Combination snap - in mounting and model FP is not possible

Accessories

- radiation shield (HA010501)
- filter caps (HA0101xx)

EE21