

EE99-1 Series

OEM - RH/T Modules

The EE99-1 OEM - RH/T modules are designed to meet the specific requirements of RH/T monitoring in climate chambers.

High-end E+E humidity sensor elements of the HC series and accurate temperature compensation of the humidity reading result in an excellent accuracy over a broad measurement range.

The analogue output for relative humidity is 4 - 20mA / 3-wire. The passive temperature output can be connected via 3-wire to an external readout.

Easy mounting and service is possible with a plug-in screw terminals block and by push buttons for field calibration.



EE99-1

Sensor Coating

Operation in heavily polluted and/or corrosive environments is typical for many industrial processes and can lead to drift or damage of the humidity sensor and therefore to incorrect measurements. The unique protective coating developed by E+E for the sensing probe (ordering code: - HC01) means a significant improvement of the long-term stability of the transmitter in very dirty and aggressive environments.

Typical Applications

climate chambers
 drying chambers

Features

remote sensing probe up to 10m (32.8ft)
 accuracy $\pm 2\%$ RH
 traceable calibration
 working range humidity 0...100% RH
 working range temperature -50...180°C (-58...356°F) / up to 200°C (392°F) short term
 passive 3-wire temperature output
 easy field calibration

Technical Data

Measured quantities

Relative humidity

Humidity sensor	HC1000-400	
Working range	0...100% RH	
Accuracy incl. hysteresis and nonlinearity with		
- special calibration against certified standards	$\pm 1\%$ (0...90% RH)	$\pm 2\%$ (90...100% RH)
- standard calibration	$\pm 2\%$ (0...90% RH)	$\pm 3\%$ (90...100% RH)
Output signal	Traceable to intern. standards, administrated by NIST, PTB, BEV... 4 - 20mA (3-wire)	
Response time with filter at 20°C (68°F) / t_{90}	< 15 sec.	

Temperature

Temperature sensor element ¹⁾	Pt100 resp. Pt1000 (class A, DIN EN 60751) see Ordering Guide	
Working range	-50...180°C (-58...356°F) / up to 200°C (392°F) short term	

General Data

Supply voltage	10 - 35V DC or 10 - 28V AC	
Load resistor for 4 - 20 mA output	10 - 35V DC	$R_L < \frac{U_v - 5V}{0.02 A}$ [Ω] (max. 350 Ω)
	10 - 28V AC	$R_L < 350 \Omega$
Current consumption	for DC supply < 32mA	for AC supply < 60mA _{eff}
Working temperature range electronics	-40...60°C (-40...140°F)	
Storage temperature range	-40...60°C (-40...140°F)	
Electrical connection	pluggable screw terminals up to max. 1.5mm ² (AWG 16)	
Sensor protection	stainless steel grid filter	
Electromagnetic compatibility	Designed for installment in and with other equipment (OEM) Measurements according to EN61000-4-3 and EN61000-4-6 FCC Part15 ClassB ICES-003 ClassB	

1) max. power dissipation 1mW

Mounting Dimensions (mm)

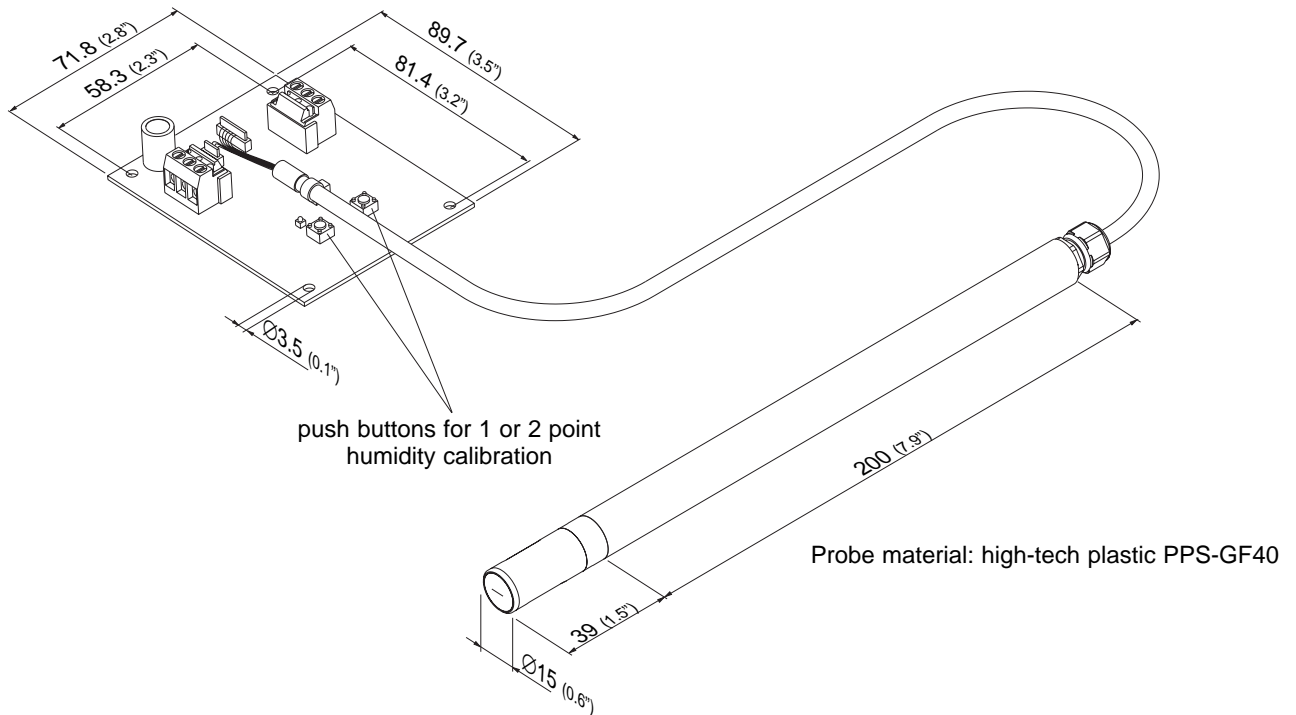

Connection Diagram

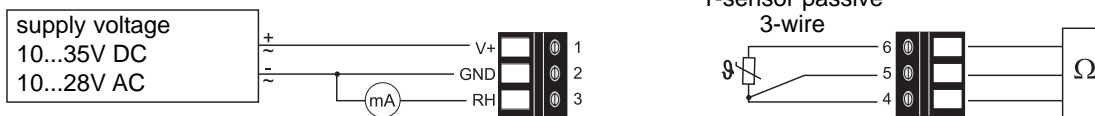

Ordering Guide

MODEL	OUTPUT	T-SENSOR	VERSION	FILTER	CABLE LENGTH
Humidity + Temperature passive (FP)	4 - 20 mA (6)	Pt100 DIN A (A)	remote sensing probe (D)	stainless steel grid filter (8)	2m (6.6ft) (02)
		Pt1000 DIN A (C)			5m (16.4ft) (05)
					10m (32.8ft) (10)
EE99-1-					

PROBE LENGTH	SENSOR COATING	CALIBRATION
200mm (7.9") (5)	without coating (-) with coating (HC01)	standard (-) high humidity calibration (CA01)

Order Example

EE99-1-FP6AD8025

Model: Humidity + Temperature passive
Output: 4 - 20mA
T-Sensor: Pt100 DIN A
Version: remote sensing probe
Filter: stainless steel grid filter
Cable length: 2m (6.6ft)
Probe length: 200mm (7.9")
Coating sensor: without coating
Calibration: standard